

Clarke®

X-PRO



3/4" AIR IMPACT WRENCH

MODEL NO: CAT204

PART NO: 3120521

OPERATING & MAINTENANCE INSTRUCTIONS

UK
CA | CE

ORIGINAL INSTRUCTIONS

GC02/22 - Rev 1

INTRODUCTION

Thank you for purchasing this CLARKE Impact Wrench.

Please read all of the safety and operating instructions carefully before using this product. In doing so you will ensure the safety of yourself and that of others around you, and you can look forward to your purchase giving you long and satisfactory service.

Please keep these instructions in a safe place for future reference.

SPECIFICATION

Model Number	CAT204
Part Number(s)	3120521
Min. Hose Size (ID)	3/8" (9.5mm)
Max Operating Pressure	90 psi (6.2 bar)
Air Consumption	8.5 cfm
Drive size	3/4" Square
Max No Load Speed	9000 rpm @ 90psi
Max Torque	850 ft/lb (1150 Nm)
Torque settings	1) - 370 ft/lbs 2) - 590 ft/lbs 3) - 850 ft/lbs 4) - in reverse - 880 ft/lbs
Air Inlet Size	1/4" BSP Female
Sound Pressure Level (LpA dB)	77 dB(A)
Sound Power Level (LwA dB)	88 dB(A)
Vibration Levels	6.096 m/s ² (uncertainty factor K= 1.5m/s ²)
Weight	2.49 kg
Wrench Dimensions (L x W x H)	197 x 190 x 68 mm

GENERAL SAFETY RULES



CAUTION: FAILURE TO FOLLOW THESE PRECAUTIONS COULD RESULT IN PERSONAL INJURY, AND/OR DAMAGE TO PROPERTY.

WORK ENVIRONMENT

1. ALWAYS keep the work area clean and tidy.
2. ALWAYS Dress appropriately - Do not wear loose clothing or jewellery. Tie long hair out of the way.
3. ALWAYS Keep children and visitors away - DO NOT let children handle the air tool.
4. DO NOT operate the air tool where there are flammable liquids or gases.

USE OF POWER TOOLS

1. ALWAYS stay alert and use common sense - do not operate the tool when you are tired or under the influence of alcohol, drugs or medication.
2. ALWAYS wear eye protectors when using the tool. Eye protectors must provide protection from flying particles from the front and the side. Ear protectors should also be worn.
3. DO NOT overreach - Keep proper footing and balance at all times.
4. DO NOT use oxygen, CO², combustible gases or any type of bottled gas as a source of power for this tool.
5. DO NOT connect the air supply hose with your finger on the trigger.
6. DO NOT exceed the maximum pressure for the tool of 90 psi / 6.2 bar.
7. ALWAYS keep the air supply hose away from heat, oil and sharp edges.
8. DO NOT fit the tool to any stand or clamping device that may damage it.
9. ALWAYS Check hoses for leaks or worn condition before use, and ensure that all connections are secure.
10. DO NOT use the tool for any purpose than that described in this manual.
11. DO NOT carry out any alterations or modifications to the tool.
12. ALWAYS disconnect from the air supply when:
 - Performing any maintenance.
 - The tool is not in use.

- The air tool will be left unattended.
 - Moving to another work area.
13. DO NOT use the tool if it is defective or operating abnormally.
 14. DO NOT damage the air tool by applying excessive force.
 15. DO NOT maintain the tool with care for the best and safest performance.
 16. Quick change couplings should not be located at the tool. They add weight and could fail due to vibration.
 17. DO NOT force or misuse the tool. It will do a better and safer job at the rate for which it was designed.
 18. This tool vibrates with use. Vibration may be harmful to your hands or arms. Stop using the tool if discomfort, a tingling feeling or pain occurs. Seek medical advice before resuming use.
 19. DO NOT carry the air tool by the air hose.
 20. DO NOT carry the tool with your finger on the trigger.
 21. When not in use the air tool must be disconnected from the air supply and stored in a dry place out of the reach of children.

IMPACT WRENCH SAFETY INSTRUCTIONS

1. ALWAYS use the impact wrench as described in these instructions.
2. ALWAYS ensure the wrench is not moving and disconnected from the air supply when changing sockets etc. Use only Impact Wrench sockets....DO NOT use standard sockets.
3. ALWAYS finish tightening wheel nuts or engine parts with a torque wrench or suitable spanner to the correct torque as recommended by the vehicle manufacturer.
4. ALWAYS avoid excessive use of the wrench. When tightening a nut or bolt, only allow the wrench to impact briefly to avoid over tightening.
5. ALWAYS ensure that the socket is correctly installed before switching on.
6. ALWAYS only use sockets which are specified for impact wrench use.
7. Due to the possible presence of asbestos dust from brake linings, always wear suitable respiratory protection.
8. ALWAYS disconnect from the air supply when changing sockets or when the wrench is not required for immediate use in order to avoid accidental starting.
9. ALWAYS use both hands to control the impact wrench.
10. ALWAYS ensure the wrench has stopped before putting it down after use.

COMPRESSED AIR REQUIREMENTS



WARNING: COMPRESSED AIR CAN BE DANGEROUS. ENSURE THAT YOU ARE FAMILIAR WITH ALL PRECAUTIONS RELATING TO THE USE OF COMPRESSORS AND COMPRESSED AIR SUPPLY.

A typical air line layout is shown below. If an automatic in-line filter/regulator is used, it will keep the tool in good condition, but should be regularly checked and topped up with oil. CLARKE airline oil should be used, and the lubricator adjusted to approx 2 drops per minute.

Use only clean, dry, regulated compressed air as a power source.

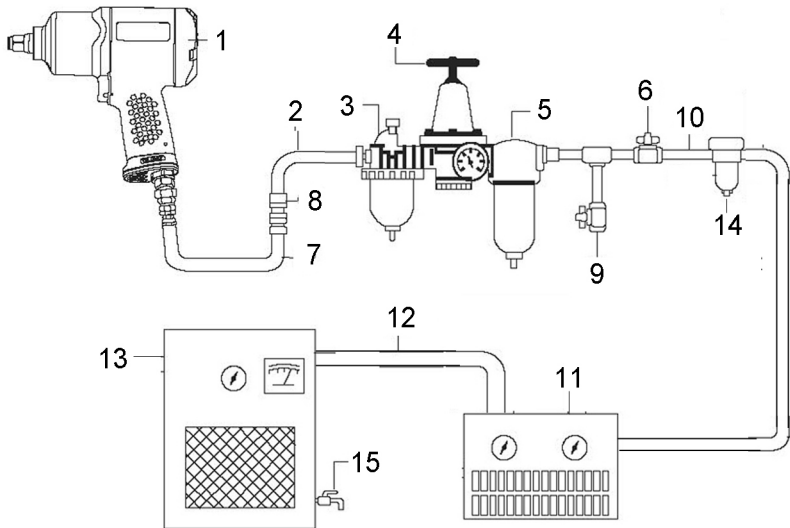

AIR SYSTEM LAYOUT :

- | | |
|-------------------------------|-------------------------------------|
| 1. Air Tool | 9. Drain Valve |
| 2. Air Hose 3/8" (I.D.) | 10. 1/2" or larger pipe and fitting |
| 3. Oiler | 11. Air Dryer |
| 4. Pressure Regulator | 12. 1" or larger pipe and fitting |
| 5. Filter | 13. Air Compressor |
| 6. Shut Off Valve | 14. Auto Drain |
| 7. Whip Hose | 15. Drain Valve |
| 8. Coupler Body And Connector | |

A build-up of moisture or oil in the air compressor will accelerate wear and corrosion in the tool. Ensure any moisture is drained from the compressor daily and the inlet filter is kept clean.

If an unusually long air hose is required, (over 8 metres), the line pressure or the hose inside diameter may need to be increased.

The air hose must be rated at least 150% of the maximum operating pressure of the tool. For best performance it is recommended that a 3/8" ID hose is used.

Never exceed the maximum operating pressure for the tool. It is recommended that air pressure to this tool does not exceed 90 psi at the tool when running. Higher pressures and dirty air will shorten the life of the tool due to faster wear and is a possible safety hazard.

PRODUCT OVERVIEW

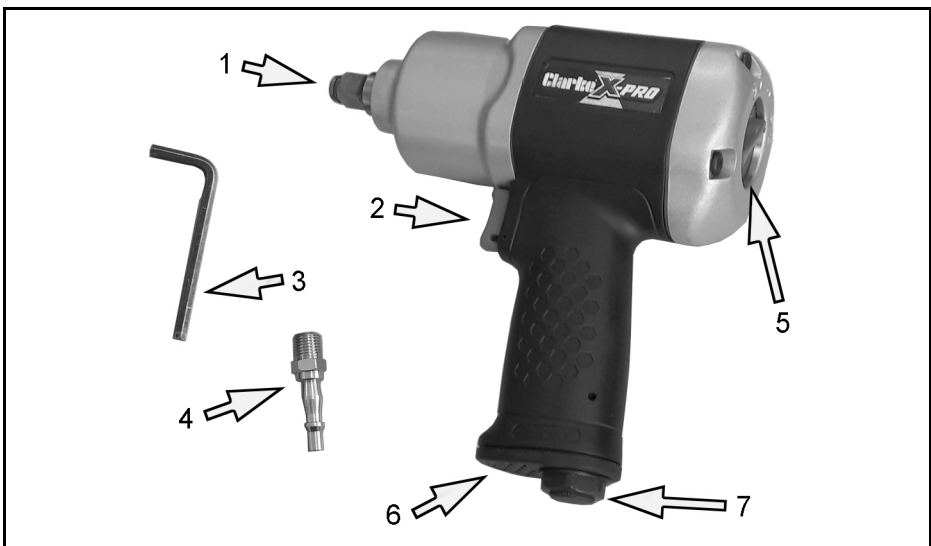

NO	DESCRIPTION	NO	DESCRIPTION
1	3/4" Square Drive	5	Direction/Speed Control
2	Trigger	6	Air exhaust
3	Allen key	7	Airline Inlet
4	Inlet adaptor		

BEFORE USE



WARNING: COMPRESSED AIR CAN BE DANGEROUS. ENSURE THAT YOU ARE FAMILIAR WITH ALL PRECAUTIONS RELATING TO THE USE OF AIR COMPRESSORS AND COMPRESSED AIR SUPPLY.

NOTE: Ensure the compressor is turned off.

1. Remove the plastic blanking plug from the air inlet connection.
2. Pour 2-3 drops of CLARKE airline oil into the oil filling port. This should be done regardless of whether or not a lubricated air supply is to be used.
3. If required, connect an in-line mini oiler to the tool.
 - A mini oiler helps to prolong the life of any air tool.

4. Connect a suitable hose as shown or use the snap connector supplied to connect directly to the hose.



5. Connect the other end of the hose to the compressor.
6. Turn on the air supply and check for air leaks. Rectify any found before proceeding.

- PTFE tape may be useful for sealing threaded connections.

7. If using a mini oiler, place a sheet of paper next the exhaust port and hold the throttle open for approximately 30 seconds. The oil volume is correctly set when a light stain of oil can be seen on the paper. Excessive oil should be avoided.

Your impact wrench is now ready for use.

OPERATION

FITTING THE IMPACT SOCKET



WARNING: NEVER USE STANDARD SOCKETS. THESE MAY SHATTER WITH SERIOUS CONSEQUENCES. ONLY USE IMPACT SOCKETS DESIGNED FOR USE WITH IMPACT TOOLS.

1. Select the impact socket you require, which must be in good condition and fit the tool exactly.
2. Push the socket onto the 3/4" square drive shaft as shown.

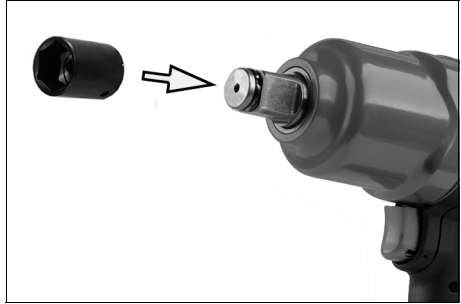

ADJUSTING THE DIRECTION AND SPEED

1. To adjust the speed, turn the switch slowly forward until the desired output is achieved.
 - Setting 1 (small dot) is the least amount of power while setting 3 (large dot) is the most powerful.
 - The wrench operates at maximum power in reverse. This setting is for releasing threaded fasteners.

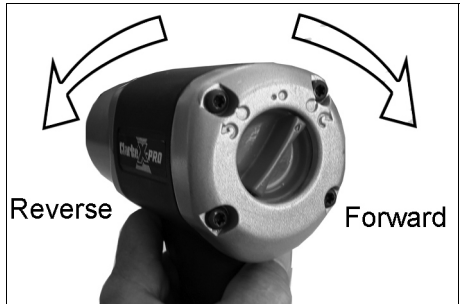

NOTE: Where the torque setting is critical, the final tightening must be by hand using a correctly calibrated torque wrench.



WARNING: WAIT UNTIL THE WRENCH HAS STOPPED ROTATING BEFORE OPERATING THE FORWARD/REVERSE SWITCH.

LOOSENING A WHEEL NUT/BOLT

1. Remove any wheel trim, before selecting the appropriate socket and placing firmly on the square drive of the wrench.
2. With the control switch in the REVERSE running position (anti-clockwise) and holding the wrench firmly in BOTH HANDS, squeeze the trigger. The nut will be impacted repeatedly until it is loosened. **IMPORTANT!** Release the trigger as soon as the nut begins to loosen.
3. Jack up the vehicle according to the vehicles handbook so that the wheel is clear of the ground, then fully undo the wheel nuts.
4. Soak rusted nuts in penetrating oil, and break any rust seal before twisting off with the wrench.



WARNING: ENSURE THAT THE CORRECT SOCKET IS BEING USED FOR THE NUTS/BOLTS ON YOUR PARTICULAR VEHICLE. USING AN INCORRECT SOCKET SIZE IS LIKELY TO DAMAGE THE HEADS OF THE BOLTS/NUTS.

TIGHTENING A NUT

1. Start the nut/bolt by hand, ensuring it is not cross threaded, then with the appropriate socket installed on the wrench, place it on the nut/bolt.
2. With the selector switch in the clockwise (forward running) position and holding the wrench firmly in BOTH HANDS, pull the trigger.
3. Run each nut/bolt up in turn until it is 'nipped' up only - do not tighten. When all nuts/bolts are nipped up, tighten progressively by pulling the trigger fully and allowing the action to operate briefly to prevent overtightening.
4. ALWAYS finish tightening with a torque wrench. The weight of the vehicle will need to be placed on the wheel to prevent it from rotating while the nuts/bolts are tightened. Ensure the final torque applied to the nuts/bolts meets the vehicle manufacturer's recommendations.

For torque values, see specification on page 2.

DISCONNECTING THE AIR SUPPLY

1. Do not disconnect the air hose until the supply is isolated at a shut-off valve.
2. Once the pressure has been isolated, disconnect the air supply hose from the air tool.
3. Shut down the compressor at the end of the work session.

MAINTENANCE



WARNING: MAKE SURE THAT THE WRENCH IS DISCONNECTED FROM THE AIR SUPPLY BEFORE STARTING ANY CLEANING OR MAINTENANCE PROCEDURES.

DAILY

1. Before use, drain water from the airline filter and compressor.
2. If no line lubricator or mini oiler is used, ensure that oil is applied to the tool on a daily basis through the air inlet connection. Run a few drops of oil through the tool before use. It may be entered into the tool air inlet, (ensuring the strainer is clear), or into the hose at the nearest connection to the air supply. After this you can operate the tool.
3. This procedure should be repeated after every two to three hours of use, or at the start of the working day.
4. Keep the body of the tool clean and free from debris.

WEEKLY

1. Check the air inlet screen filter for blockage and clean if necessary.

CLEANING & OVERHAUL

1. Grit or gum deposits in the tool may reduce efficiency.
2. After extensive use, remove the inlet screen filter and flush out the mechanism with gum solvent oil or an equal mixture of CLARKE air-line oil and paraffin. Allow to dry before use.
3. If the tool still runs erratically or becomes inefficient, and the air supply is of good quality, it may be necessary to dismantle the air motor and replace worn or damaged parts. You may prefer to take the tool to your CLARKE dealer if internal maintenance is required.
4. The air tool may be dismantled by unfastening the bolts and removing the rear cover prior to replacing any worn or damaged parts.
5. While in a dismantled state, it may be desirable to grease the hammer mechanism and applying a small amount of good quality bearing grease.

This may be better left to your CLARKE dealer.

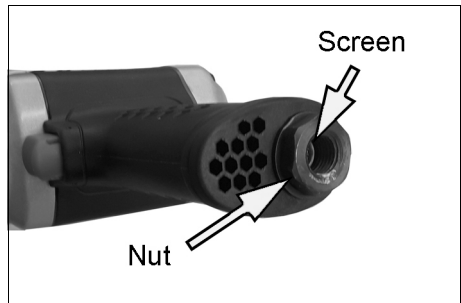

TROUBLESHOOTING

SYMPTOM	PROBLEM	SOLUTION
Tool runs at normal speed but slows down under any load.	<ol style="list-style-type: none"> 1. Motor parts worn. 2. Worn or sticking mechanism due to lack of lubricant. 	<ol style="list-style-type: none"> 1. Return to CLARKE dealer for repair. 2. Drip air tool lubricating oil into air inlet. Allow oil to soak moving parts before using.
Tool runs slowly. Air flows weakly from exhaust.	<ol style="list-style-type: none"> 1. Motor parts jammed with gum/dirt. 2. Air-line regulator in closed position. 3. General airflow blocked by dirt. 	<ol style="list-style-type: none"> 1. Examine inlet air filter for blockage and clean if necessary. Drip a few drops of air tool lubricating oil into air inlet. 2. Adjust in-line regulator to open position. 3. Operate tool in short bursts.
Tool will not run. Air flows freely from exhaust.	<ol style="list-style-type: none"> 1. Motor vanes stuck due to buildup of foreign material. 	<ol style="list-style-type: none"> 1. Disconnect air supply and rotate tool assembly manually. 2. Try operating tool in short bursts. 3. Tap motor housing gently with a rubber mallet. 4. Drip a few drops of air tool lubricating oil into air inlet to soak moving parts.
Tool will not shut off.	<ol style="list-style-type: none"> 1. Throttle O-rings damaged or ill-fitting in seat. 	<ol style="list-style-type: none"> 1. Return to CLARKE dealer for repair.

PERFORMANCE

Please note that outside factors may affect the operation and efficiency of the air tool.

These include reduced compressor output, excessive drain on the airline, moisture ingress, restrictions in the air-line such as the use of connectors of incorrect size or poor condition which will reduce the air supply.

Your air tool has been designed to give long & trouble free service. If, however, having followed the instructions in this booklet carefully you encounter problems, take the unit to your local CLARKE dealer.

Any major servicing and repairs should be carried out by your local CLARKE dealer or a qualified service technician.

STORAGE

If the tool is to be stored, or is idle for longer than 24 hours, run a few drops of CLARKE air line oil into the air inlet, and run the tool for 5 seconds in order to lubricate the internal parts. Store the tool safely in its box in a dry, secure place.

When not in use, disconnect from the air supply, clean and store in a safe, dry place. When storing, replace the blanking plug to the airline inlet.

Avoid storing the tool where the temperature is below 0°C.

ACCESSORIES

A wide range of accessories is available including filter/regulators, lubricators, high-pressure hoses (5 to 50 metres) etc.

**CLARKE Air Line Oil (part no. 3050825) is available from your CLARKE dealer.

SUITABLE CLARKE IMPACT SOCKET SETS INCLUDE:

CIS19/9M 8 piece 3/4" Metric Impact Socket Set part no 1800320

CIS19/9S 9 piece 3/4" A/F Impact Spline socket Set part no 1700725

CIS19/5S 5-piece 3/4" Impact Spline socket set part no 1700724

Contact your CLARKE dealer for further information or the CLARKE International Service Department.

GUARANTEE

This product is guaranteed against faulty manufacture for a period of 12 months from the date of purchase. Please keep your receipt which will be required as proof of purchase.

This guarantee is invalid if the product is found to have been abused or tampered with in any way, or not used for the purpose for which it was intended.

Faulty goods should be returned to their place of purchase, no product can be returned to us without prior permission.

This guarantee does not affect your statutory rights.

DECLARATION OF CONFORMITY



Fitzwilliam Hall, Fitzwilliam Place, Dublin 2

DECLARATION OF CONFORMITY

This is an important document and should be retained.

We hereby declare that this product(s) complies with the following directive(s):
2006/42/EC Machinery Directive.

The following standards have been applied to the product(s):
EN/ISO 11148-6:2012.

The technical documentation required to demonstrate that the product(s) meet(s) the requirement(s) of the aforementioned directive(s) has been compiled and is available for inspection by the relevant enforcement authorities.

The CE mark was first applied in: 2019

Product Description: 3/4" Composite Air Impact Wrench
Model number(s): CAT204
Serial / batch Number: N/A
Date of Issue: 09/02/2022

Signed:

J.A. Clarke
Director

CAT204 CE Clarke DOC 020922

Page 1 of 1



Hemnal Street, Epping, Essex CM16 4LG

DECLARATION OF CONFORMITY

This is an important document and should be retained.

We hereby declare that this product(s) complies with the following statutory requirement(s):
Supply of Machinery (Safety) Regulations 2008

The following standards have been applied to the product(s):
BS EN/ISO 11148-6:2012

The technical documentation required to demonstrate that the product(s) meet(s) the requirement(s) of the aforementioned legislation has been compiled and is available for inspection by the relevant enforcement authorities.

The UKCA mark was first applied in: 2022

Product Description: 3/4" Composite Air Impact Wrench
Model number(s): CAT204
Serial / batch Number: N/A
Date of Issue: 09/02/2022

Signed:

J.A. Clarke
Director

CAT204 UKCA Clarke DOC 020922

Page 1 of 1

COMPONENT PARTS LIST

No	Description
1	Hammer case
2	Rubber gasket
3	Anvil bushing
4	Circlip
5	O-ring
6	Anvil
7	Hammer
8	Hammer cage
9	Hammer pin
10	Trigger
11	Pin
12	Handle
13	Pin
14	Bearing
15	Front end plate
16	Pin
17	Cylinder
18	Rotor
19	Vane
20	Rear end plate

No	Description
21	Bearing
22	Rubber gasket
23	O-ring
24	Switch
25	Spring
26	Steel ball
27	O-ring
28	Back cover
29	Fastening screw
30	Inlet gasket
31	O-ring
32	Rubber gasket
33	Inlet valve
34	Inlet spring
35	Plastic cover
36	O-ring
37	Air inlet
38	Air inlet screen
39	Silencer fabric

COMPONENT PARTS DIAGRAM

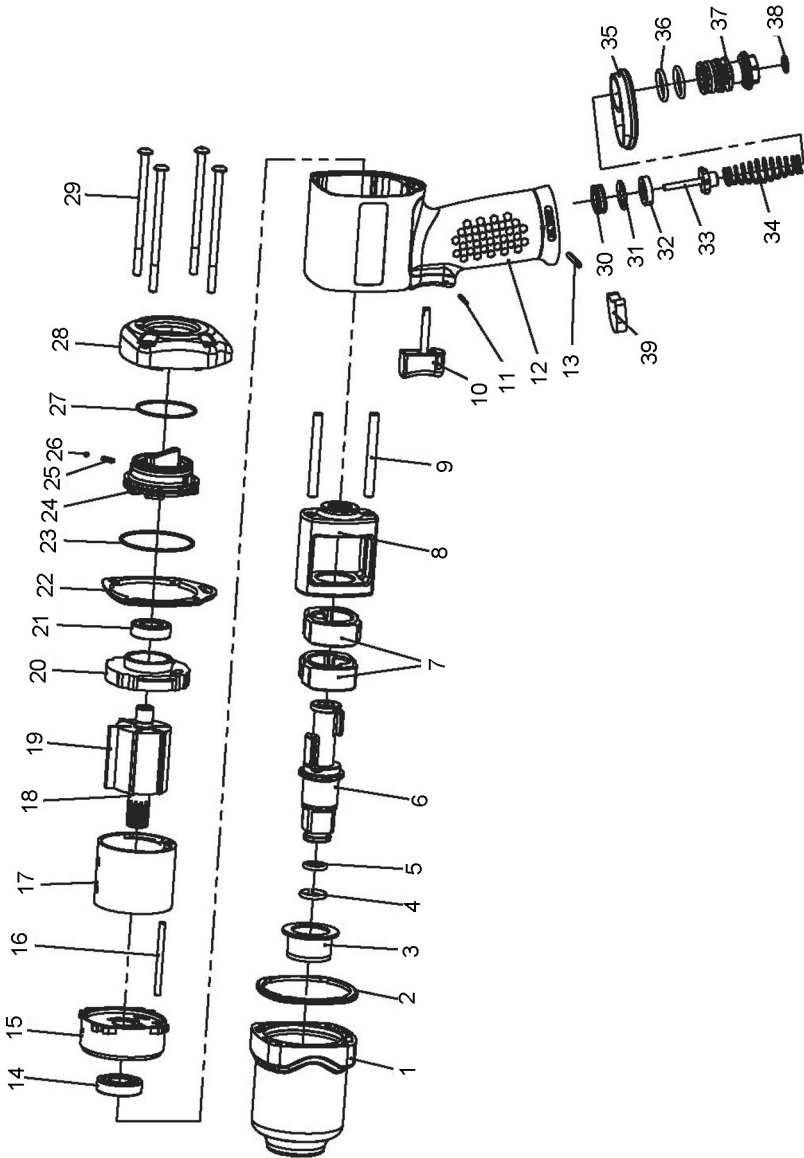

A SELECTION FROM THE VAST RANGE OF

Clarke®

QUALITY PRODUCTS



AIR COMPRESSORS

From DIY to industrial, Plus air tools, spray guns and accessories.

GENERATORS

Prime duty or emergency standby for business, home and leisure.

POWER WASHERS

Hot and cold, electric and engine driven - we have what you need

WELDERS

Mig, Arc, Tig and Spot. From DIY to auto/industrial.

METALWORKING

Drills, grinders and saws for DIY and professional use.

WOODWORKING

Saws, sanders, lathes, mortisers and dust extraction.

HYDRAULICS

Cranes, body repair kits, transmission jacks for all types of workshop use.

WATER PUMPS

Submersible, electric and engine driven for DIY, agriculture and industry.

POWER TOOLS

Angle grinders, cordless drill sets, saws and sanders.

STARTERS/CHARGERS

All sizes for car and commercial use.

PARTS & SERVICE:

0208 988 7400

Parts Enquiries

Parts@clarkeinternational.com

Servicing & Technical Enquiries

Service@clarkeinternational.com

SALES: UK 01992 565333 or Export 00 44 (0)1992 565335

Clarke INTERNATIONAL Hemnall Street, Epping, Essex CM16 4LG
www.clarkeinternational.com